

FIG13.



Anti-Lift Block
(head jamb)

Stationary Panel

Bottom Wind Stopper

Active # Panel
10x2" Panhead
Screw

FIG20.

Caulking

Nailing Fin

Siding

Caulking



Fiberglass
Hinged Patio Doors
-Gliding

8989 North Loop East
Houston Texas 77029
Sales Dept. 1-866-Doors-15
or 1-866-366-7715
www.neumadoors.com







Gliding Patio Doors

Installation and Finishing Instruction

IMPORTANT : Please read and follow all instructions before beginning. For any questions, contact your local Neuma Doors representative.





Material required to prepare :

- Shims / spacers (12 to 20) 
- 2" galvanized roofing nails (1/4 lb.) 
- 4" wide water resistance adhesive membrane 
- Silicone Sealant 
- Interior trim and / or jamb extensions (15 to 40 ft)
- #10x3" installation screws 

Tools Required:

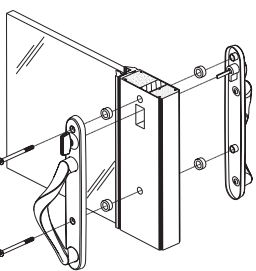
- Tape measure 
- 6' Level 
- Square 
- Hammer 
- Stapler 
- Scissors or utility knife 
- Screwdrivers (#2 Phillips & small flat blade) 
- Drill 
- 13/32" & 1/8" Drill Bits 

STANDARD PARTS SHIPPED

ILLUSTRATIONS	DESCRIPTION LOCKSET	FUNCTION	QTY		
			One Panel	Two Panel	Four Panel
	#10x2 Panhead screws	Replacement for Bottom Bracket screws	0	1	2
	#10x3 Panhead screws	Replacement for Top Bracket screws	0	2	5
			Single Point Lock(1)	Multi Point Lock(2)	Multi Point Lock(3)
	#8x3 Panhead screws	Replacement for Lock keeper screws	2	4	6

ROUGH OPENING INSPECTION

1. The rough opening should be 3/4" wider than the frame width, and 1/2" higher than the frame height.
2. Check sub for level and clean away all debris before setting door assembly. (See Fig.1)

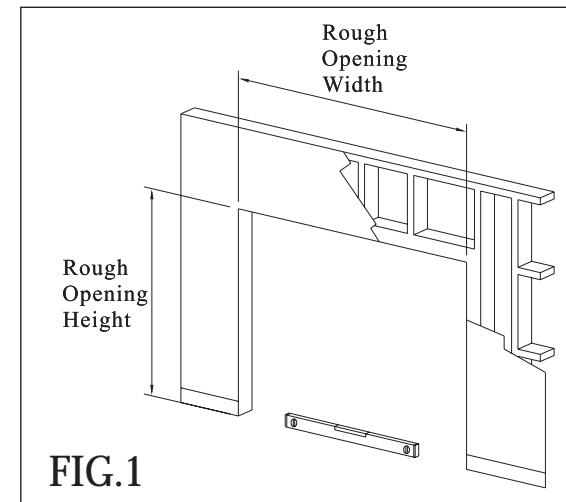

INSTALLING THE UNIT

(Active panel is locked before shipping.)

3. Before installation inspect corners of factory assembled frame for damage to the joints. If damaged reseal with a silicone or urethane sealant to eliminate chance of leakage at joint. (See Fig.2)

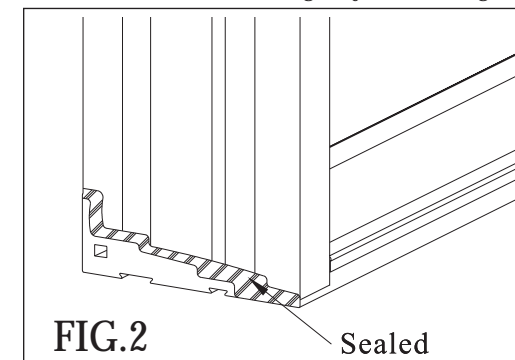

4. Apply sealant into nail fin grooves at head and jambs then snap in nail fins. (See Fig.3a)
5. Apply sealant in a continuous bead on the interior side of the nailing fin along the pre-punched holes. Proper application is sealant will squeeze through holes when unit is set against rough opening. (See Fig.3)

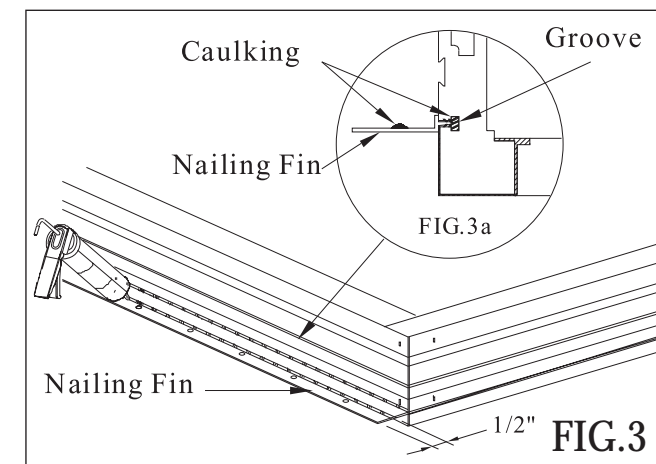

6. Apply sufficient amount of sealant along the entire length of the sub floor and 6" up each side of jambs. (See Fig.4)

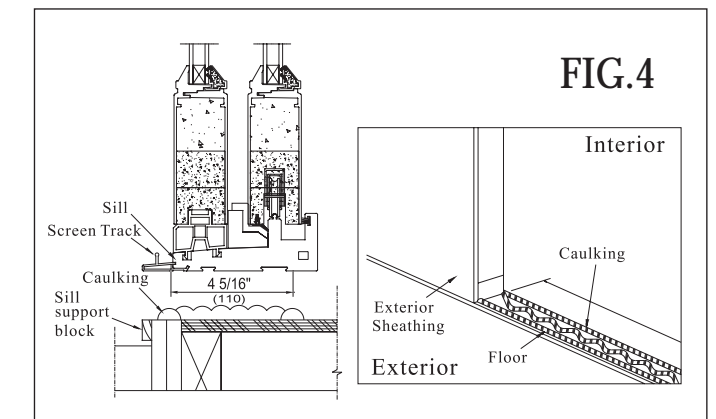

7. Move door frame into rough opening, and center it. Temporarily fix an upper corner of the nailing fin with a 2" roofing nail and secure the corner head jamb with a #10x3" flathead screw from the interior side. (See Fig.5)

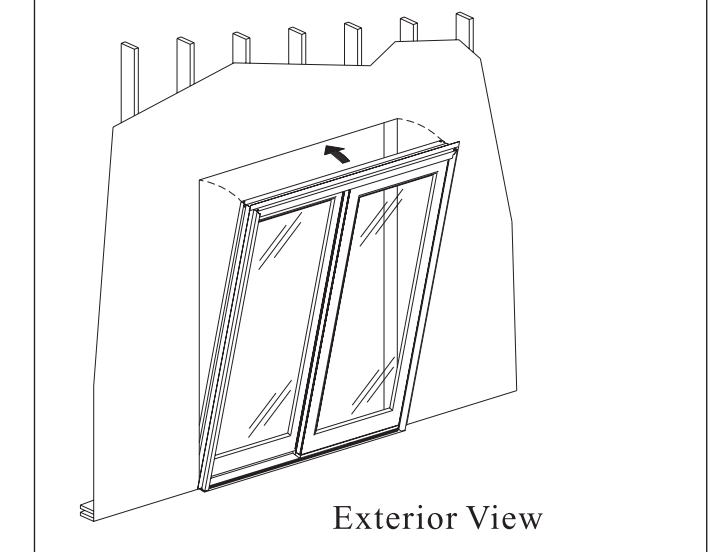
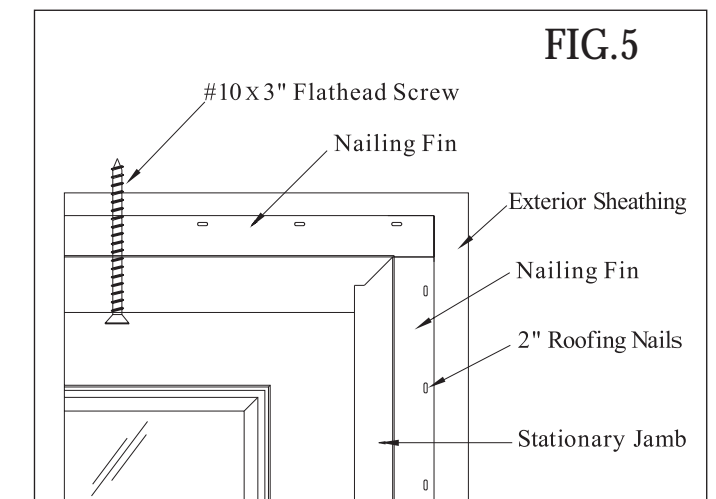

8. Use level to check if the jambs are straight and plumb. The sill must be leveled and straight. Make sure the diagonal measurements of the entire frame are equal. If necessary, shim the corners 8" from the sill and head jamb. (See Fig.6)

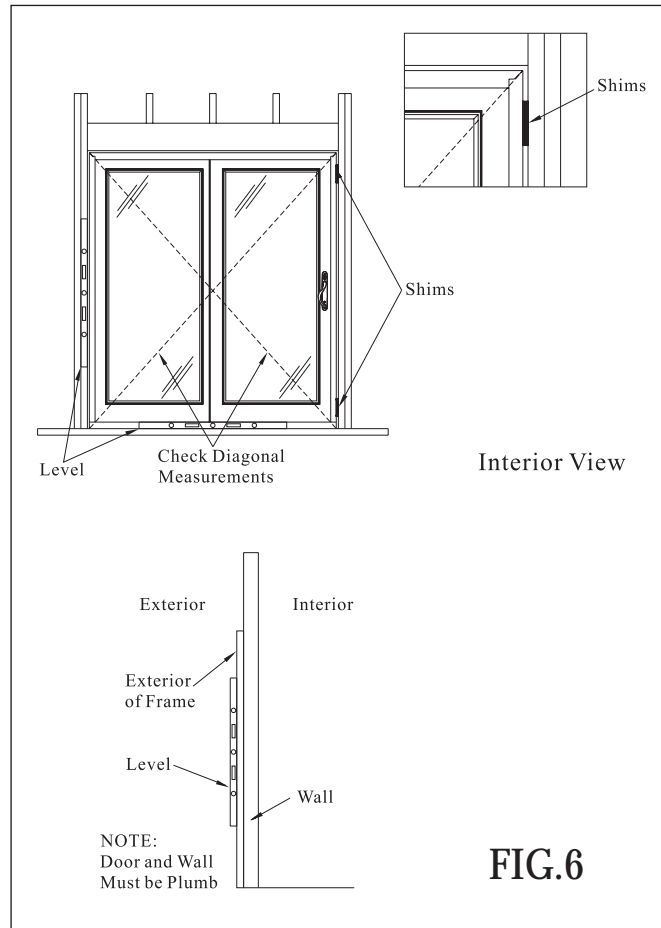

FIG.6

Use #10 x 3" flat head screw to secure the unit through the pre-drilled pilot holes through jambs. If unit is not predrilled use 1/8" bit to drill through jambs and studs at shim location. Use 13/32" bit to enlarge pre-drilled holes 1/4" deep into jambs for plug covers. (See Fig11.)

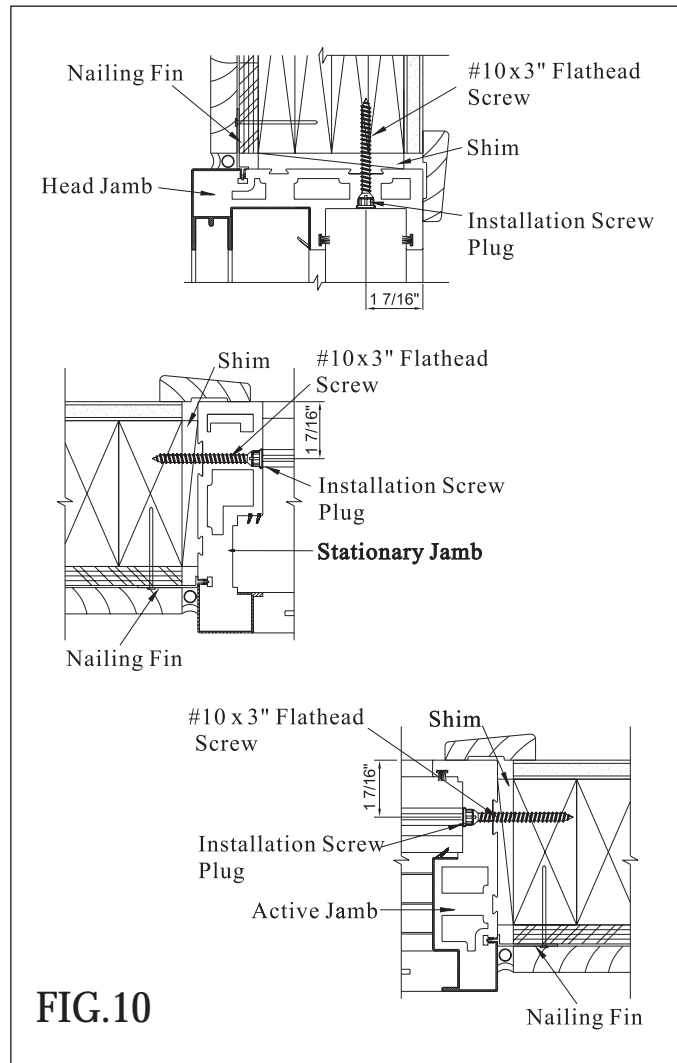

FIG.10

PERMANENTLY SECURING UNIT

9. Shim the jambs 8" down from top and up from sill. Place additional shims every 16" around jambs. (See Fig.7, Fig.8, and Fig.9) Shim at keeper location. If installation pilot holes are drilled shim at these locations. Recheck plumb level and square and adjust as necessary. Place fasteners in all prepunched holes in installation fin approximately every 7-1/4".

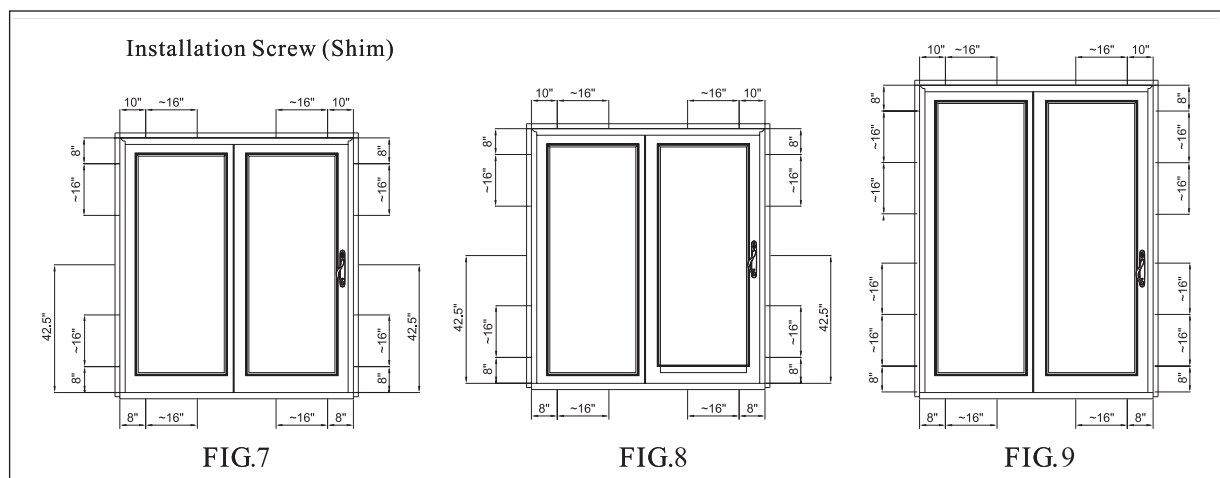

FIG.7

FIG.8

FIG.9

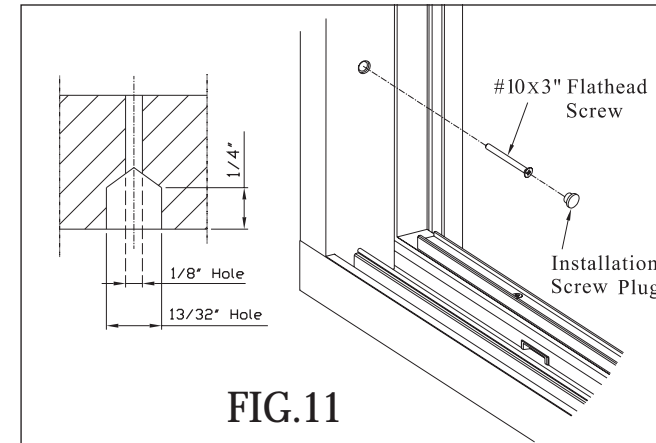
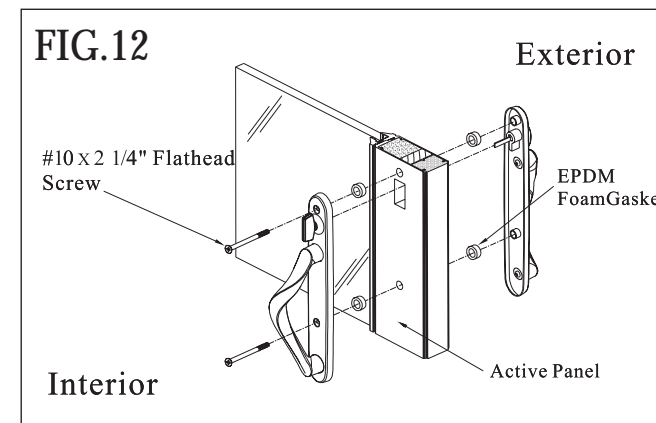

FIG.11

10. Install the lockset on the sliding or active panel. (See Fig12.)



11. Unlock door and open active panel about half the width of the panel, remove active panel by lifting panel up and out from inner side. Make sure the Anti-lift block is parallel to the head jamb. (See Fig.13), replace the two top bracket screws with #10x3" panhead screws. (See Fig.14)

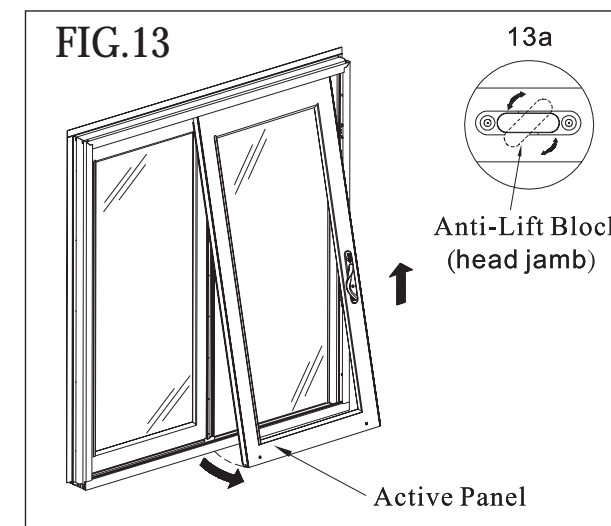

FIG.13

13a

Anti-Lift Block (head jamb)

Active Panel

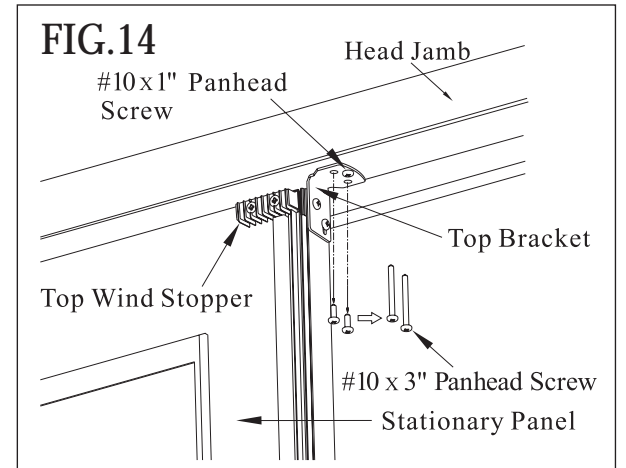

FIG.14

12. Replace keeper screws by # 8x3 "panhead screws. (See Fig.15)

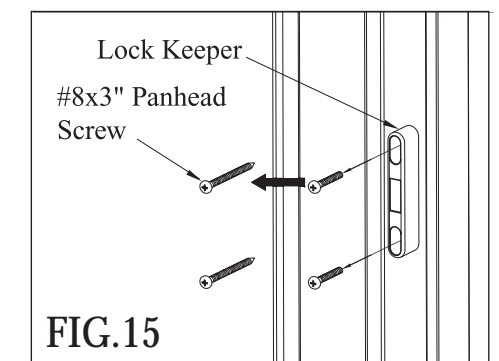

FIG.15

13. Remove bottom wind stopper and replace the bottom bracket screw with # 10x2" panhead screw. (See Fig.16)

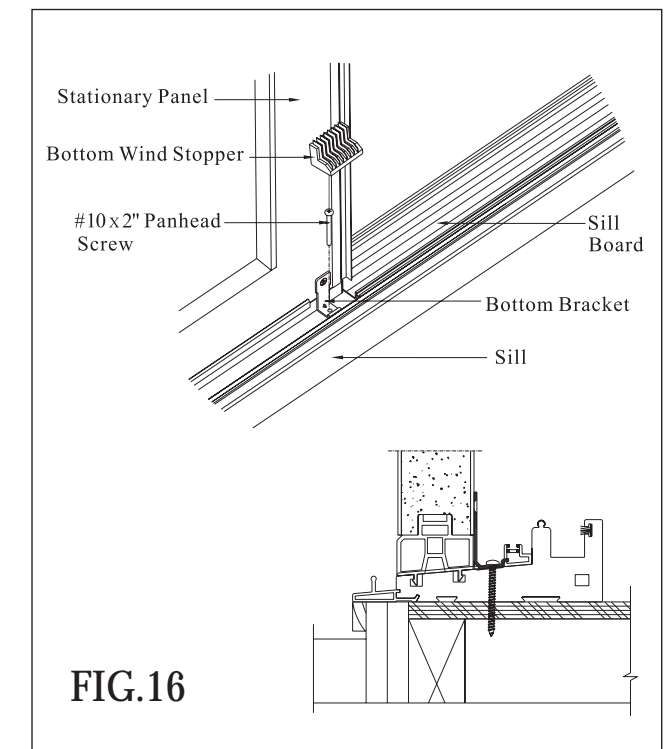
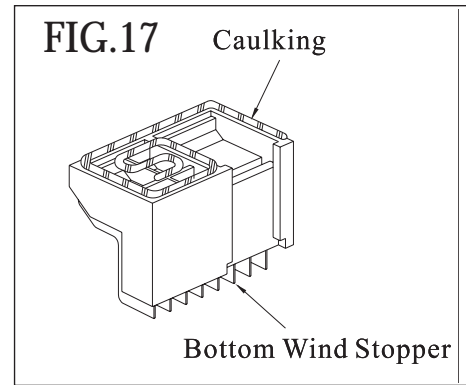

FIG.16

- Apply caulking on the backside of the bottom wind stopper and reset. Caulk between sill board and bottom wind stopper. (See Fig.17)



INSTALLING THE ACTIVE PANEL AND ADJUSTING HARDWARE

- From inside reinstall active panel by inserting top of panel into head and aligning bottom on slider track. Check for proper operation.
- If units needs further adjustment after installation follow procedure below. (See Fig.18)

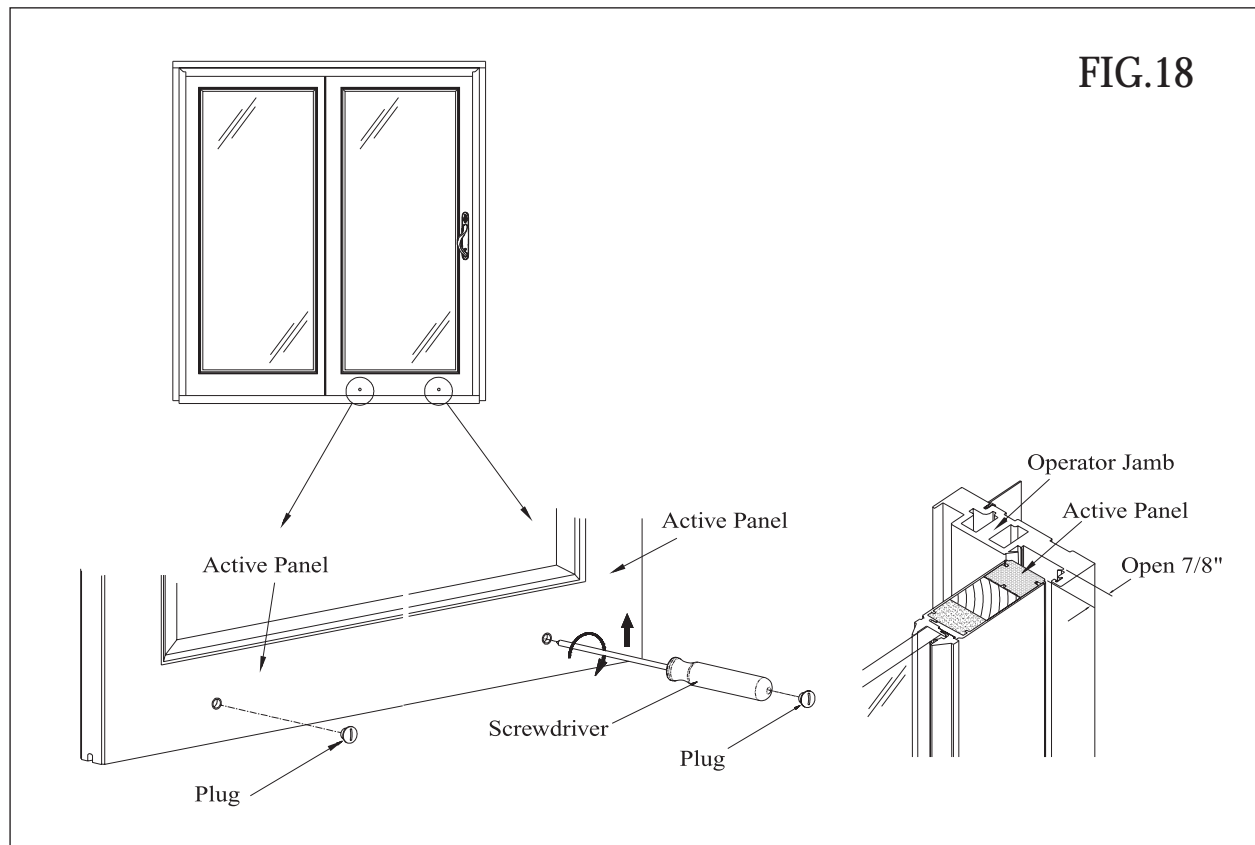

- Open the active panel approximately 7/8" from the frame, and check if the clearance between the active panel edge and side jamb is parallel.
- If the clearance is not parallel, adjust the roller by turning the roller screw. Turn clockwise to tilt the panel upwards, and turn counter-clockwise to level the panel downwards.
- Start by adjusting the roller of the jamb side. If the panel is still tilted, adjust the roller of the meeting rail side.
- Adjust the lockset and keeper to ensure proper function of the unit. (See Fig.19)
- Reset head jamb Anti-lift block. (See Fig.13a)

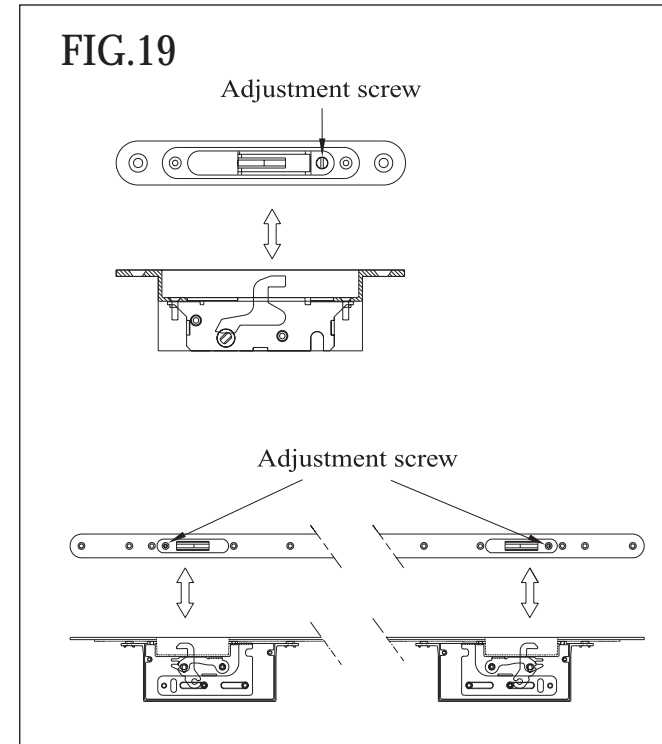

SEALING THE INSTALLATION

- Apply caulking on the top joints of the nailing fin. (See Fig.20)

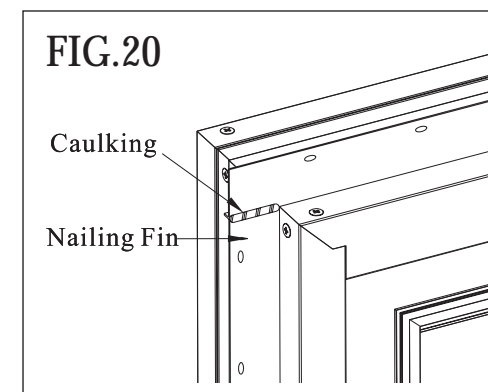

- Lap vertical strips of self sealing adhesive membrane (4" wide) onto the jambs' nailing fin and over the exterior sheathing.
- Install another layer of adhesive membrane lapping onto head jamb nailing fin and exterior sheathing. (See Fig.21)

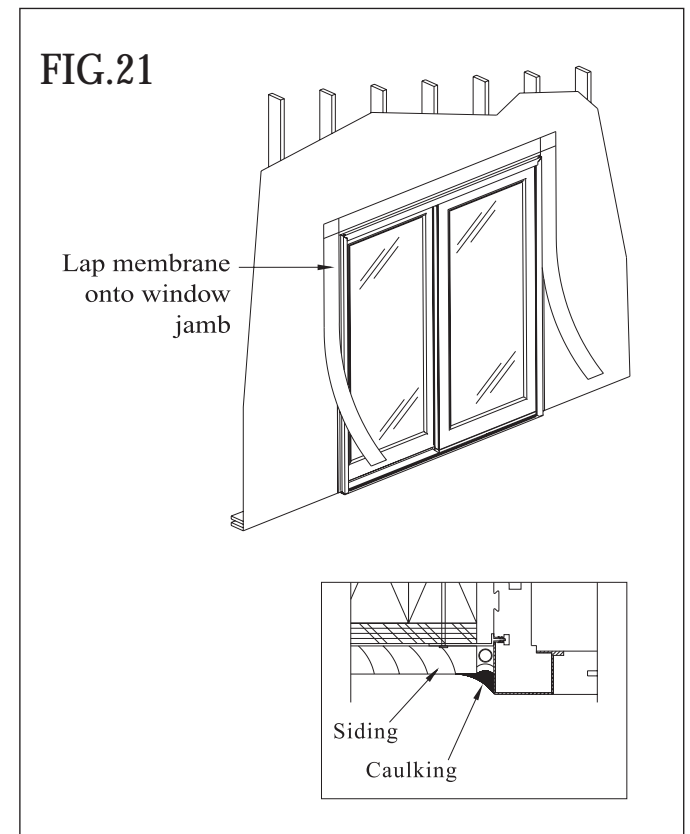

CLEANING INSTRUCTION

- Vinyl exterior part of the unit may be cleaned with mild detergent and water.
- Do not use any solvent, acids, or abrasives on the vinyl exterior.
- To clean the glass, use a soft clean grit-free cloth and mild detergent.
- Keep weep holes clean and clear of obstructions.